

QUALITY CARES.



All around sustainable

X Tepex[®]

QUALITY WORKS.

LANXESS
Energizing Chemistry

SUSTAINABILITY

- 3 About Bond-Laminates
- 4 Sustainability
- 6 Our Tepex® Products

RECYCLABLE

- 12 Recyclable
- 14 Recycling
- 15 Renewable Raw Materials

WE CARE

- 23 Sustainability in Action
- 25 Disclaimer

SAFE

- 8 Advantages of Thermoplastics
- 10 Closing Loops
- 11 Climate Protection Goals

REUSABLE

- 19 Production and Processing Technology
- 20 Integration
- 21 Overview & Outlook



ABOUT BOND-LAMINATES

The thermoplastic fiber composite **Tepex®** was developed in the 1990s and has since been produced by Bond-Laminates GmbH, based in Brilon, Germany. In 2012, Bond-Laminates became a wholly owned affiliate of LANXESS Deutschland GmbH. LANXESS, a leading specialty chemicals group, develops, produces and markets chemical intermediates, additives, specialty chemicals and plastics.

As affiliate of LANXESS Performance Materials GmbH, Bond-Laminates can offer, among other things, customized material combinations of diverse fiber types with high-performance plastics for customer-specific requirements. The thermoplastic range includes various polyamides from the **Durethan®** series, as well as polycarbonates, polyolefins and thermoplastic polyurethanes.

SUSTAINABILITY.

one goal – many aspects



In June 1972, the UN World Environment Conference was held in Stockholm - the first of its kind and also an international platform for the modern understanding of sustainability, which has continued to evolve ever since. The same year saw the publication of the Club of Rome's widely acclaimed report „The Limits to Growth,“ which called for a „state of ecological and economic equilibrium.“ Fifty years later, there is still a lot to do, but awareness of resource conservation, environmental and climate protection, and the preservation of natural habitats and biodiversity has grown and continues to grow.

A look at the 2015 United Nations Agenda 2030 shows how broad the components of sustainability are. Its guiding principle is to enable a decent life worldwide while permanently preserving the natural foundations of life. The individual goals cover economic, ecological and social aspects. Politics, business, science, civil society and each individual bear joint responsibility for a better future.

Goals of the UN 2030 Agenda for sustainable development

European industrial production is also increasingly geared toward sustainability focusing on three aspects, products, processes and people. In this way, it meets the fundamental requirements of the European Green Deal. The Green Deal identifies climate change and environmental degradation as existential threats to Europe and the world. The declared aim of the Green Deal is to create a modern, resource-efficient and competitive economy that

- emits no net greenhouse gases by 2050,
- decouples its growth from resource use,
- leaves no one, human or regional, in the lurch.



Sustainability is also becoming an increasingly important competitive factor for the economy and thus also a key driver for the transformation toward a biobased economy or a circular economy.



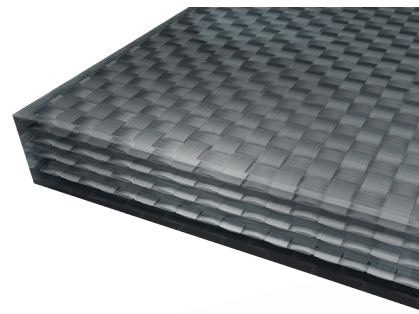

Tepex®

Key properties

- Plastic composite panels with tailored property profile made of continuous fibers in thermoplastic polymer matrix.
- Reinforced with fully impregnated and consolidated fibers of different materials
- Can be combined with injection molding in plastic/plastic hybrid technology

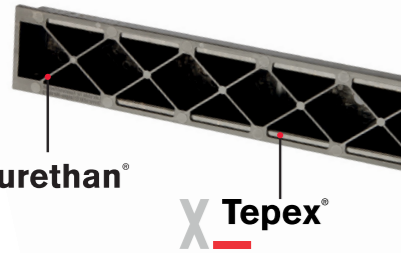

Tepex®

Benefits

- Excellent mechanical properties
- Suitable for series production due to short cycle times
- Efficient due to fully automated, integrated processing procedures
- Thermoplastic-based, therefore easy to recycle
- Ideal lightweight material

Key properties and advantages of the Tepex® composite material.

OUR TEPEX® PRODUCTS

for your applications

The path to a more sustainable future is based, to a large extent, on the conscious and economical use of resources and energy. This applies to all areas of engineered mobility. Lightweight construction is a very effective method for saving materials and thus reducing the energy required for movement or acceleration.

This makes lightweight construction attractive primarily in automotive and aircraft manufacturing, as well as for boats or unmanned aerial vehicles such as drones. Moving machine parts, for example industrial robots, also open up interesting potential applications.

Other areas of application include sports and leisure, e.g. components of racing bicycles, and housings, for example for laptops or cell phones.

Tepex® is the composite material family of Bond-Laminates. The thermoplastic matrix, which completely embeds and encases the reinforcing fibers without significant air inclusions, distinguishes Tepex®, making it an ideal material for lightweight construction - not least in terms of recycling and circular economy (see p. 10).

Lightweight materials are characterized by low weight combined with high mechanical resistance and load-bearing capacity. If the energy input for production is relatively low, then the material has a small overall CO₂ footprint. This means maximum climate protection due to minimal energy input and emissions during production and use.

A qualitative comparison of plastic composite materials with metallic materials makes this advantage clear: The ordinate intercept of the respective straight line corresponds to the CO₂ emissions during the production of an exemplarily selected component. These are usually higher for metallic materials than for glass fiber (GF) composite material, obtained from a melt. Composites reinforced with carbon fibers (CF) tend to perform worse because fiber production usually requires a lot of energy.

The slope of the straight line is a measure of the emissions during the ve-

hicle's service life. It is proportional to the weight of the component and thus depends on the specific weight of the material and the design conditions resulting from the mechanical properties.

Dependence of direct emissions on the vehicle mileage for an exemplary automotive component made from different materials

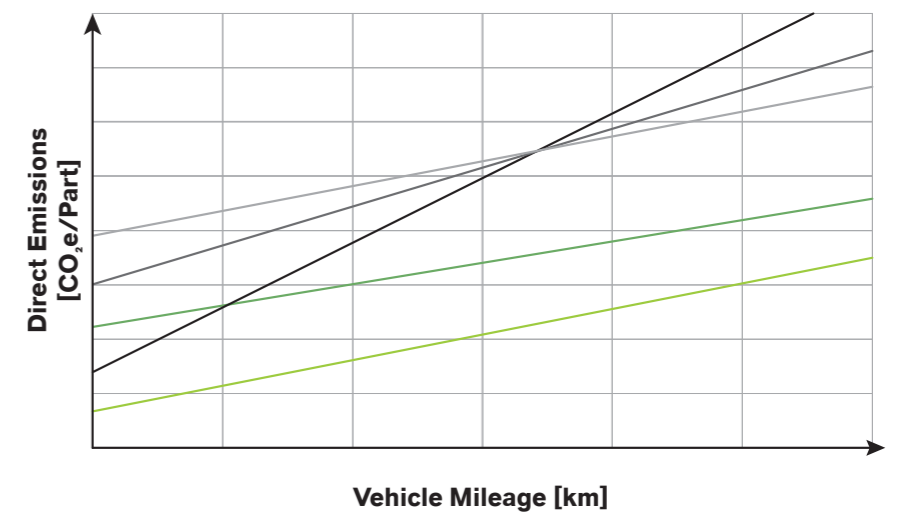

SAFE.

ADVANTAGES

of thermoplastics in terms of occupational safety

Thermoplastic matrix materials offer many advantages, both in processing and in recycling at the end of the service life.

A composite material with a thermoplastic matrix is also superior in terms of occupational hygiene. This is shown by a qualitative hazard comparison of the thermoplastic **Tepex® dymalite** with an epoxy resin-based thermoset prepreg.

Hazard classification of thermoplastic and thermoset-based composite materials in comparison (according to GHS column model (2020), source: S. Seidel, Bond-Laminates, own classification).

| Hazards | Acute health hazards | Chronic health hazards | Environmental hazards | Fire and explosion hazards | Hazards due to release | Hazards due to the procedure |
|-------------------|----------------------|------------------------|-----------------------|----------------------------|------------------------|------------------------------|
| Very high | | | | | ● | ●* |
| High | ● | | ● | | | |
| Medium | | | | | | |
| Low | | ● | | ● | | |
| Negligible | ● | ● | ● | | ● | ● |

Tepex® dymalite (hybrid molding)
Epoxy prepreg (forming + reworking)
*hand layup



CLOSING LOOPS -

reducing emissions.

Tepex®, as a semi-finished product is located in the middle of the value chain. This value chain begins with starting materials for fibers and polymers, moves to the actual raw materials (fibers or textiles and polymers) and the semi-finished products (composite sheets) then finishes with components or complex products containing these semi-finished products. Different processing techniques (black and blue arrows) are used along this path.

The possibilities for recycling production waste and trim remnants, as well as complete components at the end of their useful life, are correspondingly diverse. For example, raw materials such as fibers or mixtures of fibers and matrix can be recovered by mechanical means (lime). Alternatively, composite materials can also be returned to their original raw materials by solvolysis (dark green).

Together with partners from research and industry, Bond-Laminates has investigated such solvolysis processes for fiber-reinforced thermoplastics and developed them to pilot scale, for example as part of the EU-funded Multicycle project. In this way, both fibers and matrix material can be recovered and replace virgin material in the end products. The project has laid important foundations for the sustainable use of fossil-based materials in the circular economy.

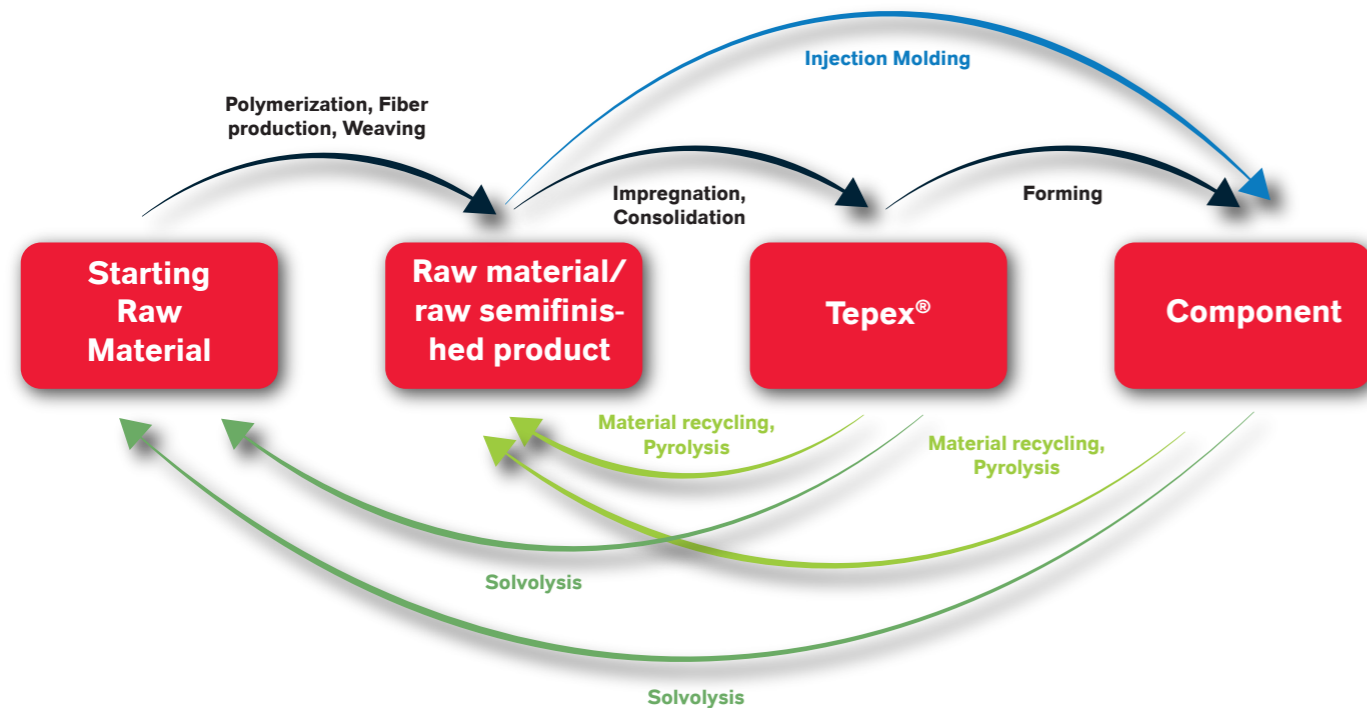

Tepex® in the value chain: production, processing, recycling

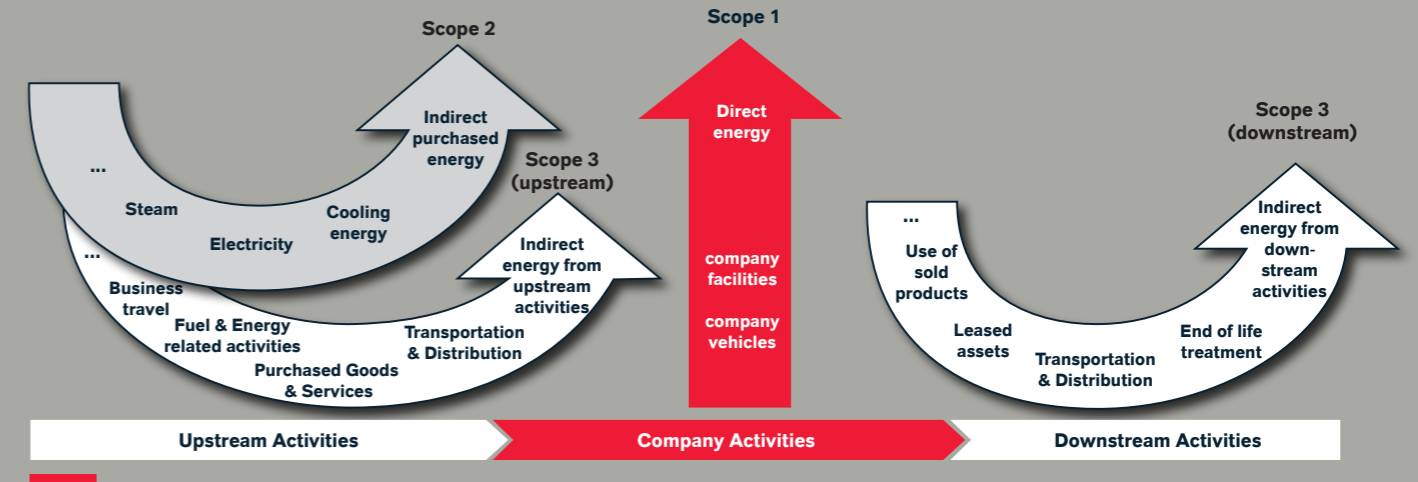

Emissions along the value chain of products from specialty chemicals group LANXESS.



SUSTAINABILITY

at LANXESS: Ambitious climate protection targets

Climate protection and the reduction of greenhouse gas emissions play a key role in LANXESS' comprehensive sustainability strategy. This is the only way to achieve the company's ambitious goals, first and foremost its own climate neutrality for Scope 1 and 2 by 2040, and Scope 3 by 2050. This requires continuous efforts to increase energy efficiency and to decouple energy requirements from growth.

This requires a reduction in emissions across the entire value chain, from direct emissions from the company's own production (Scope 1) to purchased and used energies (Scope 2) and indirect emissions from supporting services (Scope 3) such as logistics. However, by far the most significant contribution to Scope 3 emissions for Bond-Laminates is the purchased and processed raw materials. These account for over 90% of the total carbon footprint for most Tepex® grades.

Further information:

- LANXESS Sustainability Report, https://lanxess.com/-/media/Project/Lanxess/Corporate-Internet/Responsibility/Corporate-Responsibility/Corporate-Responsibility-Report-2021_EN.pdf, recalled on 09-22
- LANXESS Sustainability brochure, https://lanxess.com/-/media/Project/Lanxess/Corporate-Internet/Responsibility/Corporate-Responsibility/CR-Brochure_EN-2022.pdf, recalled on 09-22
- LANXESS climate goal, <https://lanxess.com/en/Responsibility/Climate-Neutral-2040> recalled on 09-22



RECYCLABLE.

Mechanical and material



A practical recycling concept already exists for industrial waste, primarily trim offcuts from **Tepex®** processing, in which the waste is ground up and then used for overmolding semi-finished sheets or could be used for conventional injection molding. Already today the process is used for the polypropylene (PP) and polyamide (PA) GF composites post-industrial waste. Fibers and matrix remain unseparated. The process was investigated and evaluated both economically and ecologically for PP-GF composites as part of the **ReproOrgano** project.

Complex components can be manufactured in this way, such as the support for an automobile back seat bench, which at around 5 KG, would weigh only half as much as a comparable metal component. This avenue of thermoplastic recycling is advantageous over thermosets, because for thermoset composite systems, such as those produced with continuous fibers in a RTM (resin transfer molding) process, the most that could be considered is thermal recycling, e.g. in a cement kiln, but not mechanical recycling.

Another recycling concept is based on the reuse of the fiber content, coming from old composites, production waste from fiber fabric manufacture and a thermoplastic from other sources. This has been implemented, for example, in the manufacture of laptop housings from a PC-CF composite. The polycarbonate comes from recycled bottles for water dispensers, while the carbon fibers are obtained from any waste streams and then processed into fiber mats as the core of a sandwich structure. Many of the laptop's structural components consist of around 30% PC-CF injection molded recycle, and half of the composite display lid. The flexural strength of the recycled composite almost reaches those

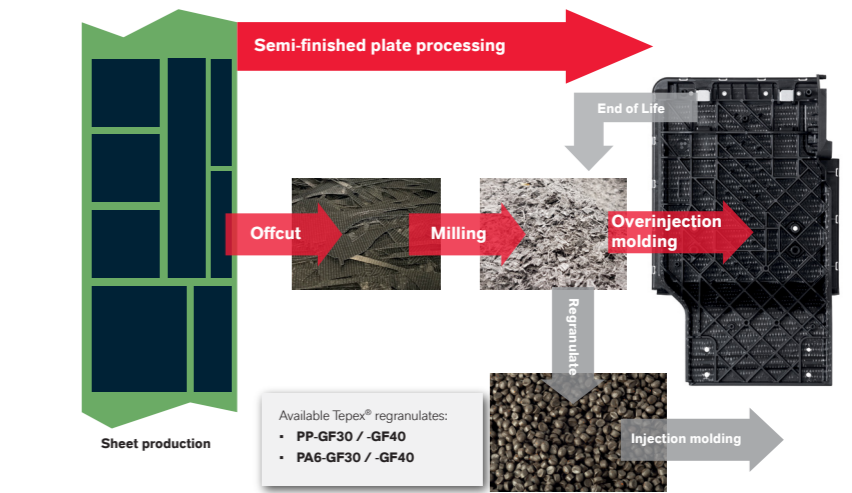

Material recycling of ground trim remnants of **Tepex®** processing in injection molding

Carbon Fiber Waste (Post-Industrial)



Non-Woven (NW) Carbon Mat



Post-Consumer Waste → Polymer recyclates

Use of CF waste and PC recycle in laptop cases.

of a composite system with a conventional core made of glass fiber fabrics.

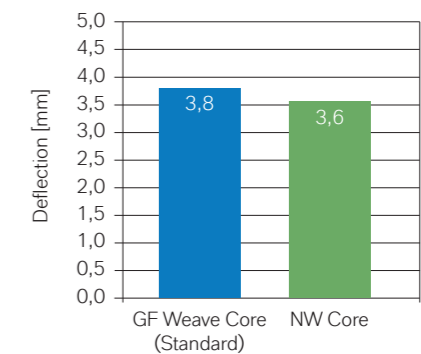
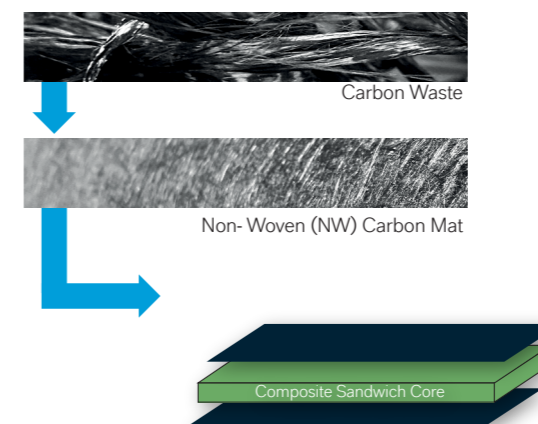

Highly bend-resistant composite systems with mats made of recycled, isotropically distributed carbon fibers as a sandwich core (**Bond-Laminates**, own measurements)



Shredded postindustrial waste (postconsumptive waste/EOL parts possible).



Mixing with new granules (enables seamless processing on standard lines)

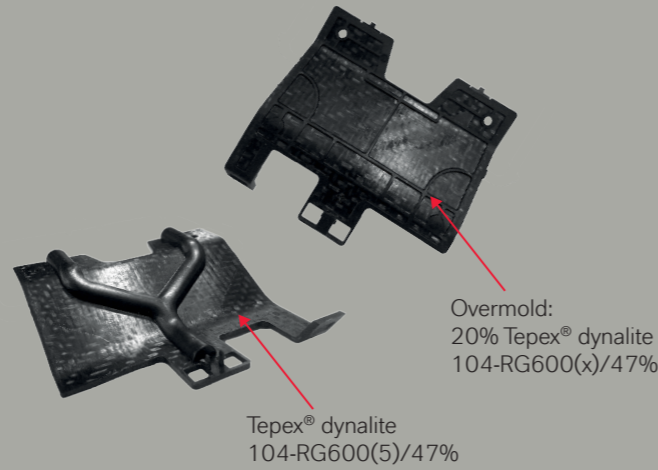

RECYCLING of thermoplastic composites.

Composites with thermoplastics other than PC can also be ground and further processed in injection molding. Component manufacturers can also efficiently recycle their own production waste, possibly even “end of life” components, so that a comprehensive material cycle can be realized.

This has been shown by studies conducted by Bond-Laminates in cooperation with the Institute of Polymer Processing (KTP) at the University of Paderborn. Using a demonstrator - similar to a component from large-scale automotive production - it was proved that ground production waste is suitable for the injection molding of functional elements. Market acceptance for such a process requires that processing can be carried out in existing machines without significant adjustment of the operating mode. Trials prove that this is possible.

Essential prerequisites for economic recycling of “end-of-life” components are and remain:

- Organization and operation of a suitable return infrastructure
- Availability of components of the correct type after dismantling (if necessary, cleaning and removal of attachments or surface layers such as paint or foils);
- Continuous availability of material of consistent quality and quantity.



RENEWABLE RAW MATERIALS

In addition to circular processes of recycling and increased energy efficiency, renewable raw materials open up an attractive way to reduce greenhouse gas emissions, as they bind carbon dioxide in the course of their production.

A comparison of the carbon footprint of different fiber materials shows differences by a factor of 30 between carbon and flax fibers.

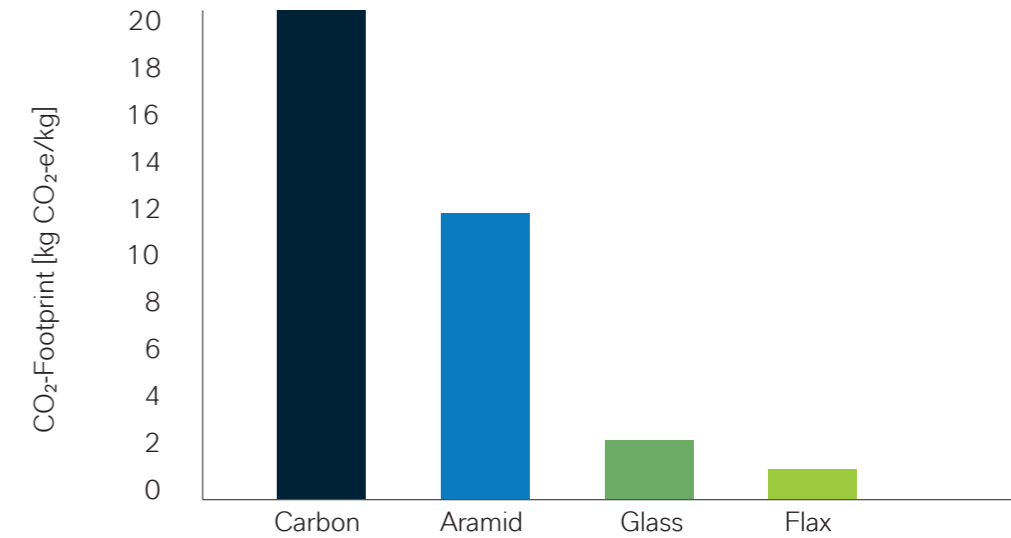

CO₂ footprint of different reinforcing fibers

Combining a renewable fiber such as flax with an equally renewable matrix material such as polylactic acid (Polylactide, PLA) provides the greatest possible reduction in the CO₂ footprint resulting to about 1/3 of a conventional PC/GF system.

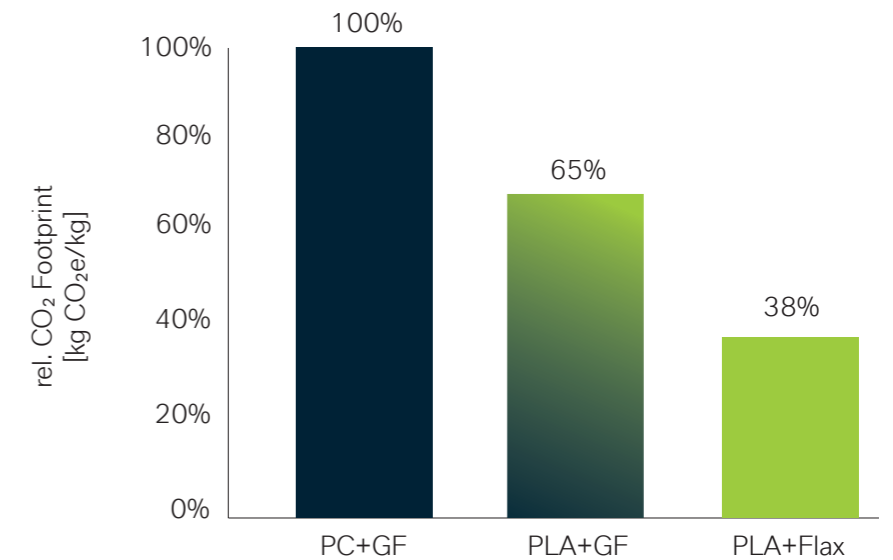

Relative carbon footprint of different Tepex® grades. (source: Bond-Laminates, own calculations)

This renewable composite system by far exceeds LANXESS' requirements for a particularly sustainable product in the Scopeblue® range. These are:

- a share of renewable or recycled raw materials above 50 percent, or
- a more than 50 percent reduction in greenhouse gas emissions relative to the conventionally manufactured product.

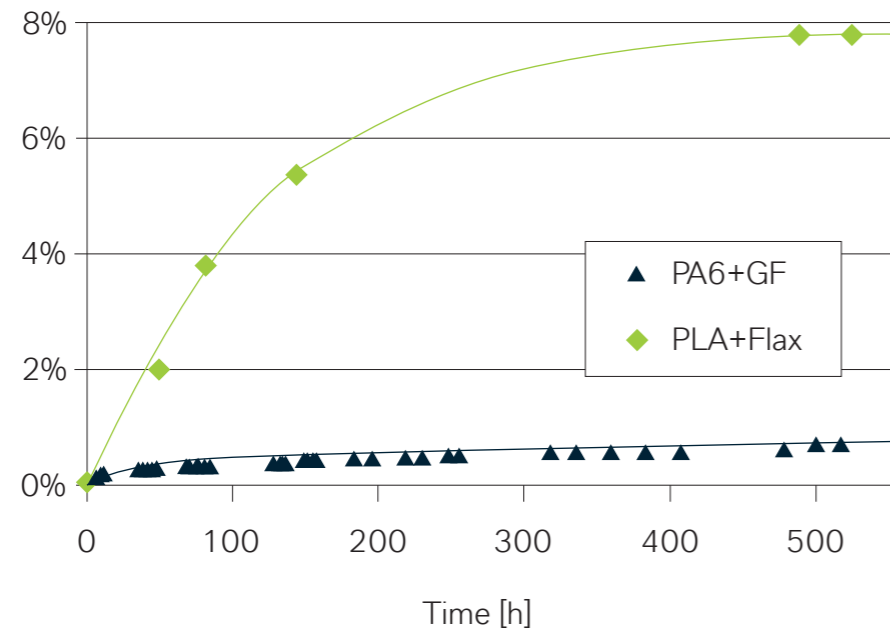

Relative water absorption (mass increase/dry mass) of composite materials in comparison (source: Bond-Laminates, own measurements).

Bond-Laminates now produces flax/PLA semi-finished products of high quality, in quantities suitable for large-scale production. Due to the low specific gravity of the fibers, the density of the composite material is also reduced by about 1/4 compared to a PC/GF composite. The high elastic makes the material particularly interesting for applications in the sports sector. The

natural fibers also have a „natural“ coloration and an attractive fabric appearance.

However, some limitations must be taken into account. Flax fibers, and thus the regarding composite, are highly hygroscopic if the fibers are exposed. In addition, the processing temperature is limited to around 200 °C due to ther-

mal degradation of the fibers and the concluding irreversible discoloration.

PLA is transparent and quite resistant to UV radiation, but has limited resistance to hydrolysis. The continuous use temperature is a maximum of 60 °C; significantly higher temperatures can be tolerated in the short term.



CONCLUSION

Incorporating renewable materials, in turn providing greater sustainability, might result in a modified property profile. This should not be seen as a disadvantage, rather an opportunity to identify applications that will work well with these new properties. Examples include housings for electronic devices, hard-shell luggage and transport boxes, and sports shoe soles. The attractive appearance, which is due to the presence of the flax fibers, is an additional benefit of the sustainable composite systems. In any case, the persuasion work that needs to be done on the way to broad market acceptance is worthwhile.

REUSABLE.



Mechanical properties of different Tepex® combinations (normalized to 45 Vol.-%)

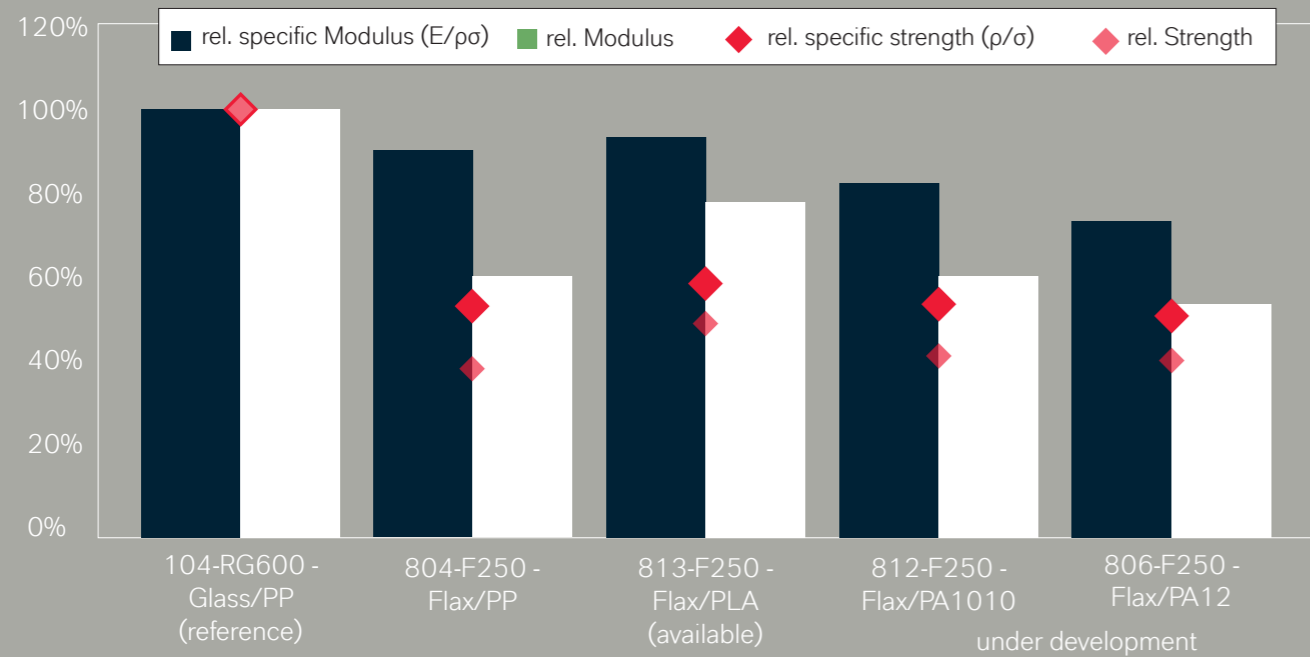

- Properties of flax/PLA and flax/PA10.10 (castor oil-based) almost reaches flax/PA12 (petroleum-based).
- Mechanical load capacity of flax/PLA is lower, but lower density brings weight advantage
- Good sound and vibration damping properties of flax/PLA thanks to the natural fiber

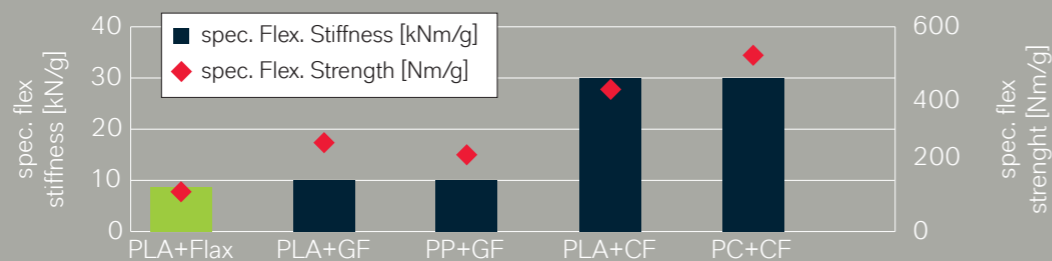

- Weight-specific stiffness of flax/PLA comparable to that of GF composites
- Strength of flax/PLA lower than GF and CF reinforced grades



PRODUCTION AND PROCESSING TECHNOLOGY

Life cycle assessments (LCAs) provide information on the potential environmental impact and energy balance of products throughout their entire life cycle. The critical factor here is the definition of the boundaries of the analysis. For example, a distinction is made between an analysis of the entire life cycle („cradle to grave“ or „cradle to cradle“) for a closed-loop process and an analysis that only extends to the respective process boundaries („cradle to gate“ or „gate to gate“).

If such a „cradle to gate“ analysis is carried out for different types of Tepex®, then, depending on the fiber and matrix material, quite different results are obtained. As expected, systems made from conventionally produced polymers with carbon fibers have by far the largest carbon footprint, while the lowest values are obtained for the 100% biobased flax/PLA systems. The share of the production phase is relatively low in all cases and quite constant at less than 0.2 kg CO₂e/kg Tepex® and is therefore allocated with a constant

share in the calculation system for all variants.

The reason for this is that Tepex® is produced from polymer and fiber material in a thermal and mechanical process without chemical reactions or direct emissions. A further reduction of the production footprint will be achieved in the future through the use of regenerative energy sources.

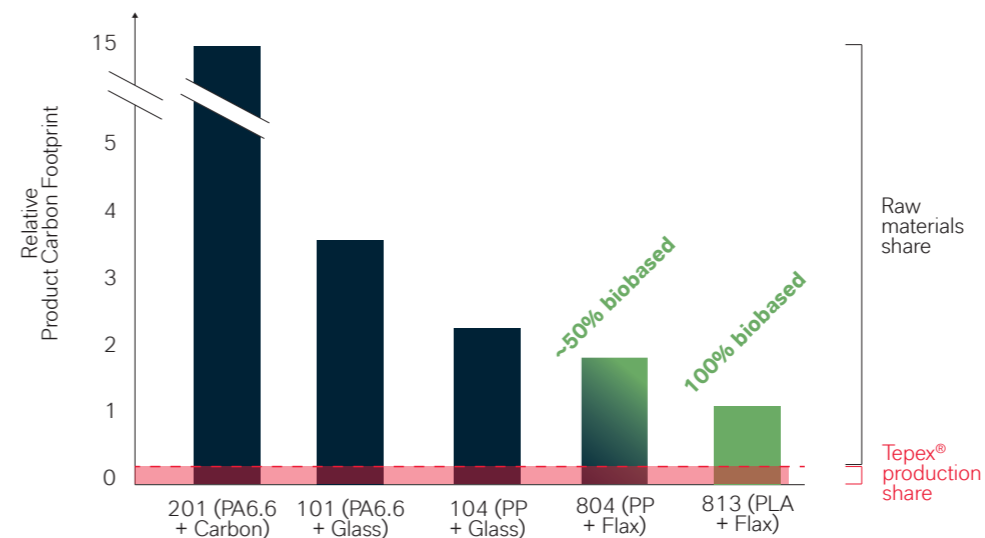

Relative carbon footprint of various Tepex® grades (normalized to a fiber content of 45%) and share of production phase

A wide range of options exist for processing the semi-finished products, depending on the type of fiber reinforcement (fabrics, nonwovens, chopped fibers), the material thickness, fiber length and the complexity or specific requirements of the component. Tailor-made processing methods offer maximum reliability, process efficiency, and energy efficiency in each case.

Component property profile as a function of fiber length and processing method for Tepex®.

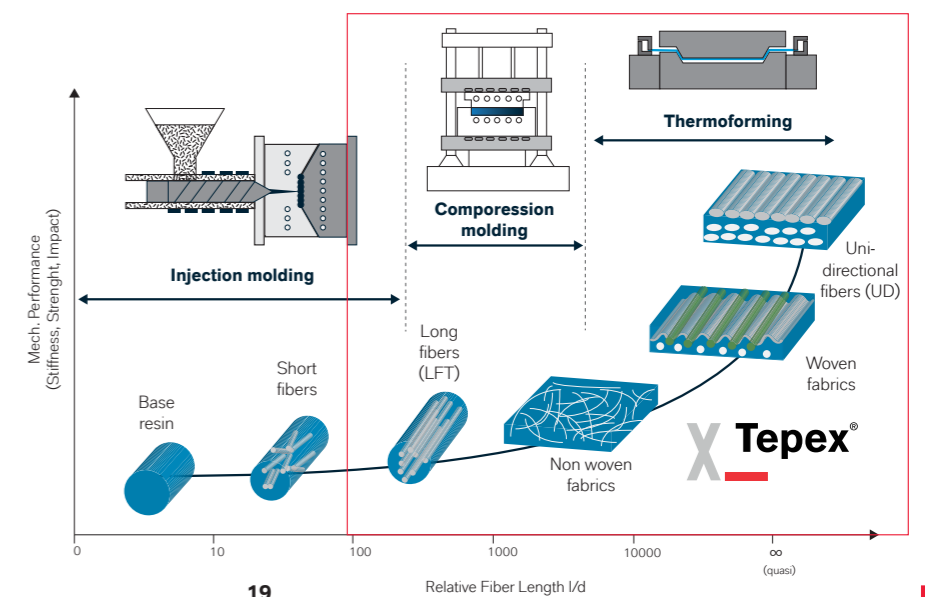

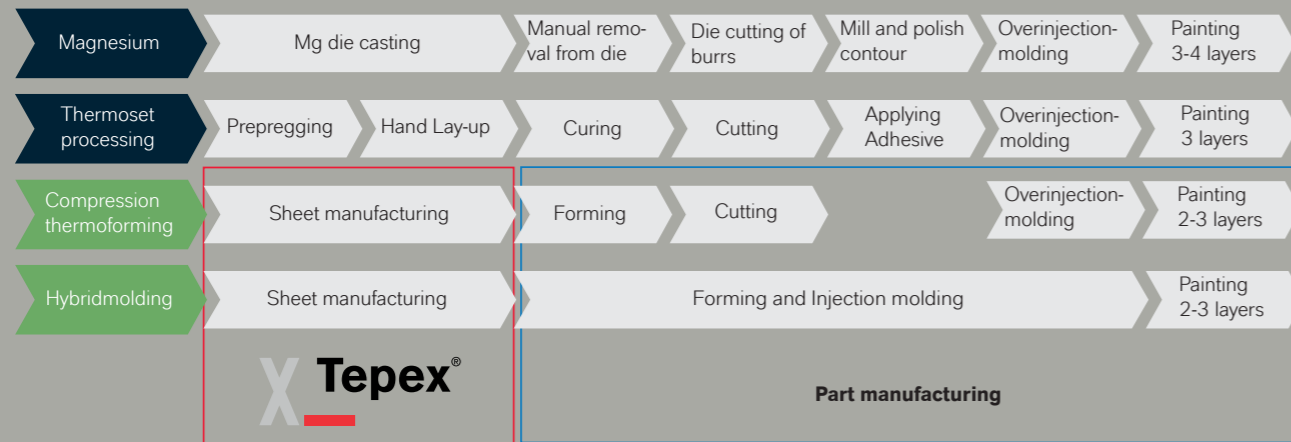

Different degrees of integration in the processing of light metal, thermosets and Tepex[®] semifinished products



INTEGRATION

saves material, time and energy

A comparison of different processing methods for light metal as well as thermoset- and thermoplastic-based composite materials makes it clear that an increasing degree of integration, as allowed by Tepex[®] semi-finished products, is associated with considerable process simplification. The risk of contamination between individual process steps is correspondingly reduced, especially when post-processing operations such as grinding or polishing are eliminated.

This is important, for example, for elaborately painted housing parts of computers or cell phones. Fewer process steps mean less manufacturing (and investment) effort for machines and equipment, and also a better energy balance, because repeated cooling and heating can be eliminated.



TEPEX[®] ON THE RIGHT TRACK -

overview and outlook.

The following overview summarizes what has been achieved so far at Bond-Laminates in terms of sustainable products. Based on recycled and bio-based raw materials, new Tepex[®] grades have been developed and launched on the market that combine an attractive sustainability profile with remarkable material properties.

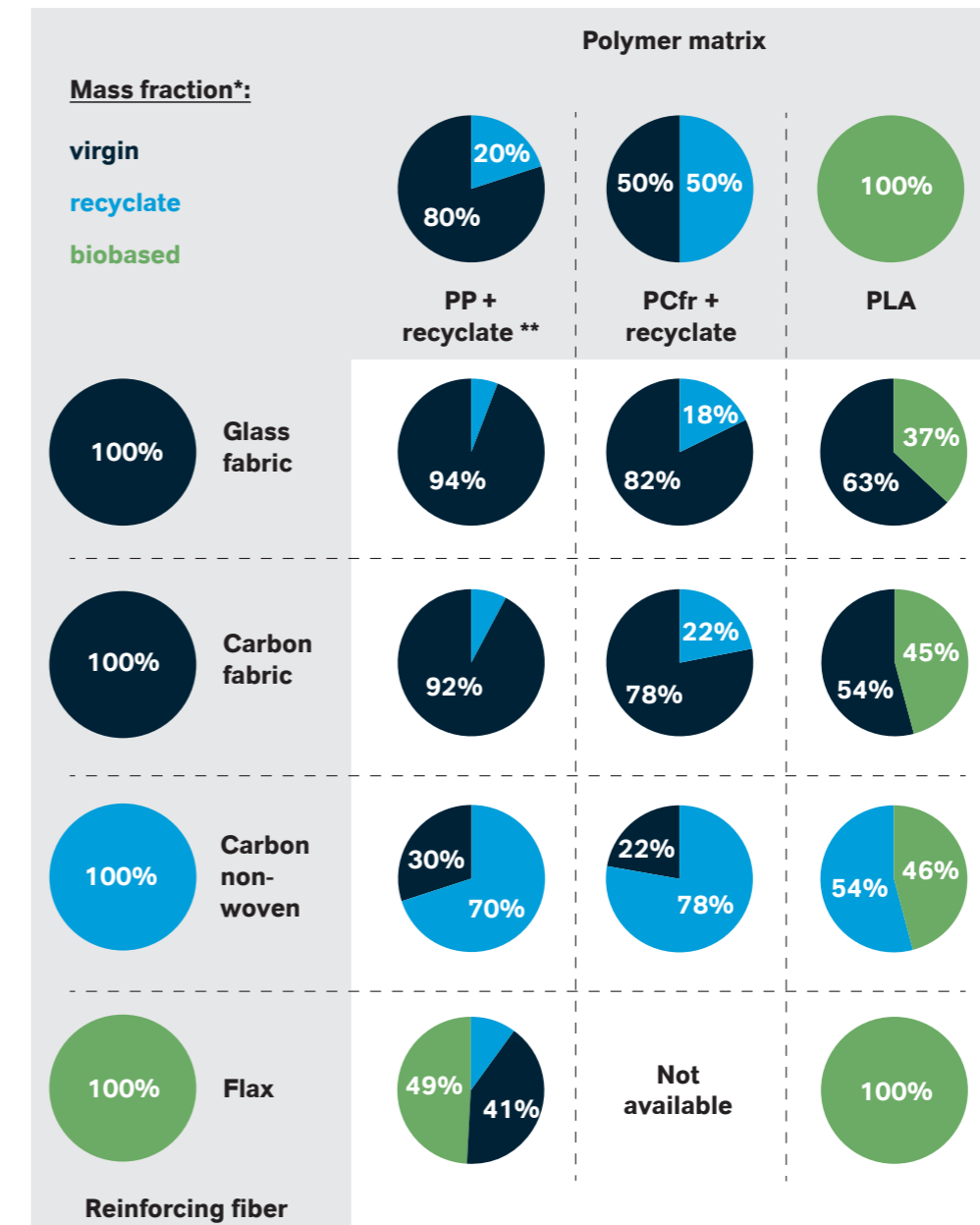

The future belongs to the use of circular and renewable raw materials. Natural fibers other than flax are also being investigated for their suitability. Research projects for the production of carbon fibers from lignin or atmospheric CO₂ previously bound by algae also are of interest. Other matrix polymers

with higher sustainability levels are also being tested. These include bio-based and circular polyamides such as Durethan[®] BLUE PA6, and PA10.10, which can be obtained from castor oil. The latter offers an alternative to PA12, which is obtained from fossil raw materials. Recycled Polyethylene terephthal-

ate (PET) which comes from beverage bottles is being looked at as a possibly cost-effective alternative to virgin PA or PC. Recycled thermoplastic polyurethanes (TPU), are also being investigated for their suitability.

WE CARE.



SUSTAINABILITY IN ACTION

The development of sustainable materials and resource-saving closed-loop models is an important part of Bond-Laminates' understanding of the future demands on lightweight materials. However, the processes in which the **Tepex®** semi-finished products are manufactured are just as important. Therefore Bond-Laminates has certified itself according to DIN EN ISO 14001 (Environmental Management) and 50001 (Energy Management) and is working on the continuous improvement of internal processes to protect resources and our environment.

In addition to processes and products, people are an essential factor in any sustainability strategy - and Bond-Laminates' employees are no exception. The aim is not only to take people with

us on the road to a more sustainable future, but also to encourage personal initiative.

One example of how our company initiative is embraced and implemented is the offer of leased bicycles, including e-bikes, for employees. This program is now used by around 1/3 of all Bond-Laminates employees.

The bicycles can be taken over by the employees at the end of the leasing period. This offer has also already been taken advantage of, so that even in the rather hilly Sauerland region, a process of rethinking sustainable mobility has undoubtedly been set in motion. In addition, the leasing offer also includes e-bikes. The next action planned is bicycle safety training - as the company's

contribution to further promoting bicycle mobility.

Another campaign is the result of an employee initiative: A tree planting campaign was financed and carried out as part of a regional reforestation concept. Due to persistent drought, bark beetle infestation, and various storms, Brilon had previously lost around 40 percent of its forest area.

With additional financial support from the company, employees helped plant around 1,500 young hornbeams and common oaks in the Brilon region in March 2022. These should be less affected by heat and drought than the earlier tree population and thus safeguard the region's recreational value and tourist appeal in the long term.





FOR A GREEN FUTURE -

We are ready.

X **Tepex**[®]

LANXESS
Energizing Chemistry

LANXESS PERFORMANCE
MATERIALS GMBH
50569 COLOGNE
GERMANY

durethan.com
pocan.com
tepex.com
info@bond-laminates.de

This information and our technical advice - whether verbal, in writing or by way of trials - are given in good faith but without warranty, and this also applies where proprietary rights of third parties are involved. Our advice does not release you from the obligation to verify the information currently provided - especially that contained in our safety data and technical information sheets - and to test our products as to their suitability for the intended processes and uses. The application, use and processing of our products and the products manufactured by you on the basis of our technical advice are beyond our control and, therefore, entirely your own responsibility.

Trial Products are sales products at the developmental stage. For this reason, no assurances can be given as to type conformity, processability, long-term performance characteristics or other production or application parameters. No definitive statements can be made regarding the behavior of the product during processing or use. The purchaser/ user uses the product entirely at his own risk. The marketing and continued supply of this material are not assured and may be discontinued at any time.

Our products are sold in accordance with the current version of our General Conditions of Sale and Delivery.

Durethan[®], Pocan[®], Tepex[®] and HiAnt[®] are registered trademarks of the LANXESS group

Order No.: LXS-HPM-082EN, Edition: 2022-10
© LANXESS Performance Materials GmbH 2022 | all rights reserved