

# QUALITY PERFORMS.

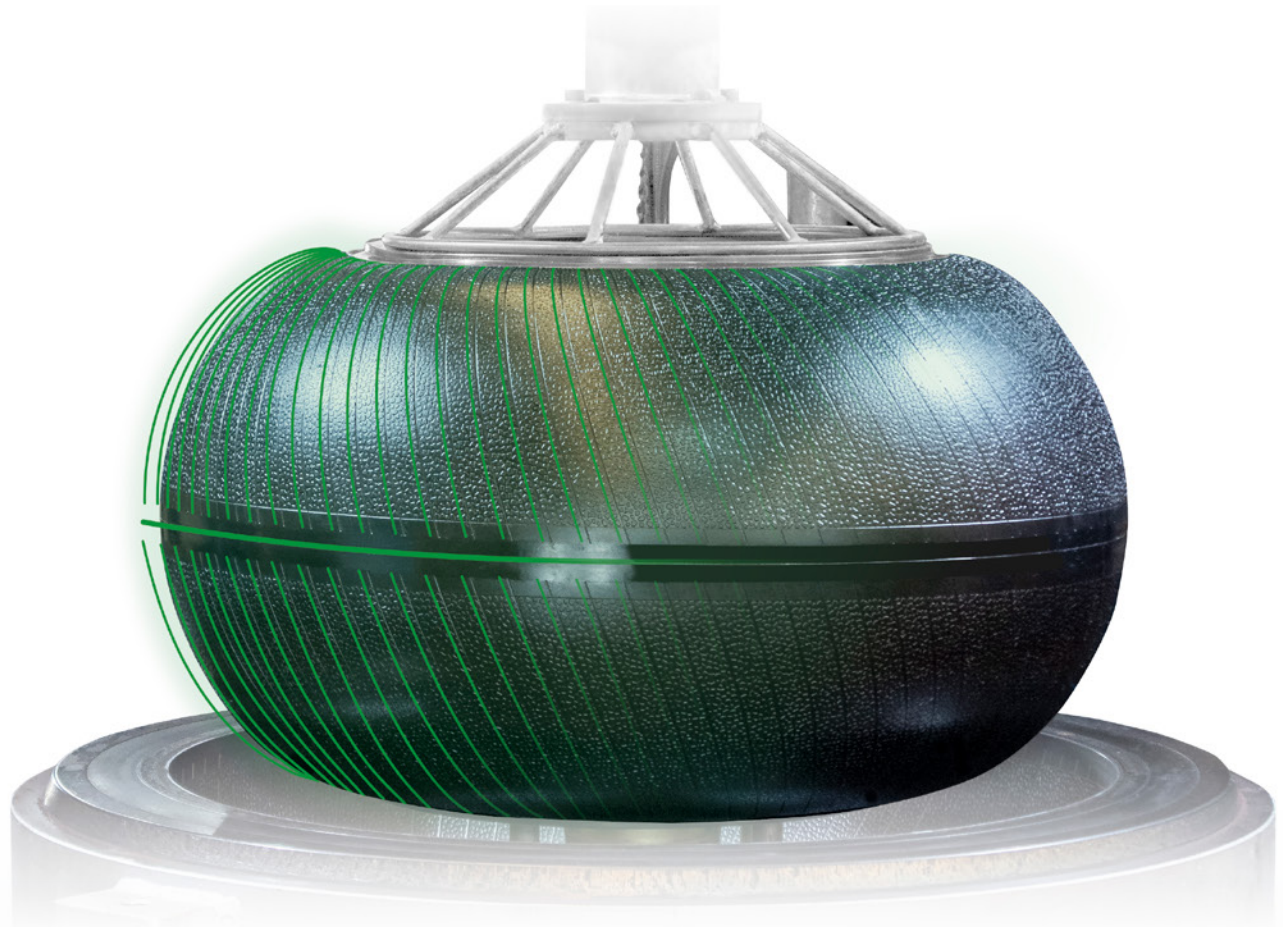

**High-performance**  
Curing bladders



**X Rhenoshape®**

**QUALITY WORKS.**

**LANXESS**  
Energizing Chemistry

# QUALITY PERFORMS.

The LANXESS Business Unit Rhein Chemie is one of the largest independent producers of tire curing bladders in the world. Marketed under the brand name **Rhenoshape®**, Rhein Chemie produces a wide range of high-performance bladders for different tire press types. Our bladders stand for increased productivity: a high number of tire vulcanisation cycles, short vulcanisation times and universally consistent high bladder quality that provides perfect tire uniformity and a low scrap rate. Rhein Chemie has three bladder production plants in different regions: Argentina, Brazil, and the USA. Rhein Chemie constantly invests in bladder-related research and development, e.g. for new compounds or bladder production processes.

We can support our customers by developing new, dedicated bladders and molds – both with compression or injection production technology. Rhein Chemie has bundled competence in bladder coating by also producing a wide portfolio of high-performance release agents marketed under the brand name **Rhenodiv®**. As one example, permanently coated bladders either allow for the complete avoidance of tire inside paints (TIP)

in the tire production process or, if used together with TIP, bladder life can be extended significantly. Rhein Chemie runs two dedicated coating lines for permanent bladder coating, one in Burzaco, Argentina and the other in Little Rock, USA. Moreover, Rhein Chemie constantly invests in its worldwide sales and distribution network in order to safeguard high supply reliability as well as local service by technical specialists in all major markets.



# SUPERB PERFORMANCE

## Wide Product Range

- Rhein Chemie manufactures over 200 different **Rhenoshape®** sizes ranging in rim diameter from 10" to 48". They cover industrial, motorcycle, passenger, light truck, agricultural, and OTR sizes produced with compression and injection molding presses ranging from 36" to 60" in width.
- The extensive **Rhenoshape®** curing bladder product line, encompassing bias and radial tire applications, is suitable for Bag-O-Matic, Krupp, NRM/Autoform, Autolok, and Kobe presses.
- We constantly develop new sizes and bladder models to suit the needs of tire manufacturers. Rhein Chemie also produces bladders using customer-supplied molds.

## Compound and Design Expertise

- The LANXESS BU Rhein Chemie has a stake in solid compound development and design tradition. These characteristics are reflected in our high quality compound portfolio (thermo-conductive and non-conductive) and also in the innovative design of vents and surface finishing, which helps release trapped air.

## Longer Bladder Life and Consistency

- **Rhenoshape®** curing bladders are easily unfolded from the start of the tire curing process because they have an inside coating. Our bladders, of every compound type, enable shorter curing cycles. Their consistent quality provides reduced press downtimes as well as reduced scrap rates for tire manufacturers. The exceptional benefits of **Rhenoshape®** types can be further extended with innovative permanent coating.

## Strict Specifications and Controls

- Thorough process controls allow us to produce in compliance with our quality standards.
- Each step of the **Rhenoshape®** production process is controlled: from supplier selection to compounding, from bladder design to storage. We cover all variables.
- **Rhenoshape®** curing bladders are subject to dimensional, RRO, rheometric, mooney viscosity, and flexometric controls.

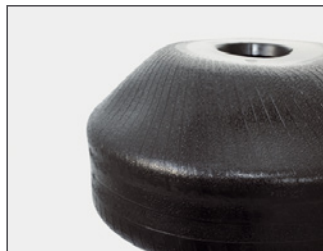

# PERMANENTLY COATED BLADDERS

■ New concepts have been developed in recent years to increase mobility and reduce noise in tires. In so-called Run On Flat tires (Pic.1), the use of classical release agents between the bladder and the tire inner surface might lead to defects in the inner liner resulting from its specific structure and the forces that arise during molding. To solve these quality problems, the LANXESS BU Rhein Chemie developed permanently coated **Rhenoshape®** bladders for the tire industry. These specially coated bladders require no additional release agents, whether applied to the bladder or the green tire, thus ensuring a smooth molding process in the tire press. In some cases, this provides a bladder service life that can otherwise be achieved only by regular recoating of the tire inner surface or the bladder.

■ Self-sealing (Sealant) and noise-reduced (Silent) tires as well as tires with sensor technology are becoming increasingly important. To ensure the adhesion of sealing layers, noise-reducing foam and sensors, the inner surfaces of tires must be cleaned extensively by laser. An advantage of using the permanently-coated **Rhenoshape®** bladders is the absence of silicone oils on the vulcanized tires, thereby eliminating interference with the application of coatings or parts after vulcanization. With the use of permanently-coated **Rhenoshape®** bladders, additional cleaning can sometimes be completely omitted (Pic. 2 and 3).

■ Permanently-coated **Rhenoshape®** bladders can be combined with all common re-coatings. Use in combination with unfilled inside paints such as **Rhenodiv®** BP-337/BP-338 or semi-permanent products such as **Rhenodiv®** SP-1003, SP-1010 or SP-1020 leads to significantly longer recoating cycles or savings in release agents. If the recoating cycles are maintained, a longer bladder life can be achieved. This is also observed when using classical, filled products such as **Rhenodiv®** BP-286 or **Rhenodiv®** BP-550. These products are also very suitable for laser cleaning. They are easy to remove with this technology and can be completely vacuumed off in the cleaning process without leaving any residue (Pic. 4).

■ Our permanently-coated **Rhenoshape®** bladders are manufactured at different locations with a highly automated process. This enables traceable high quality across the entire **Rhenoshape®** portfolio.

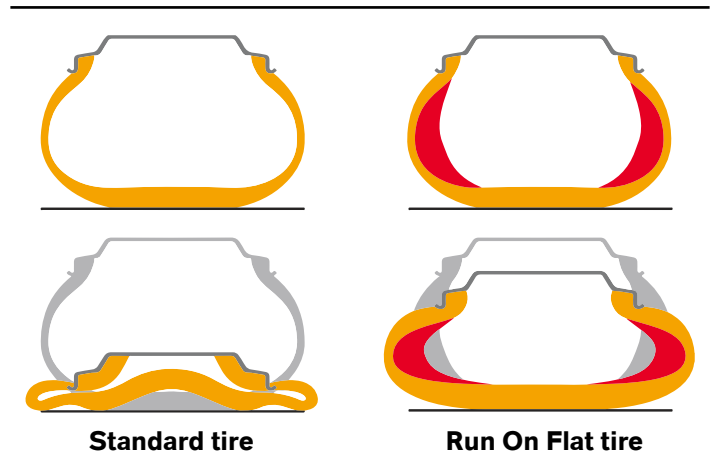

Picture 1: Standard tire (left) and self supporting run on flat tire (right) inflated and after pressure loss.

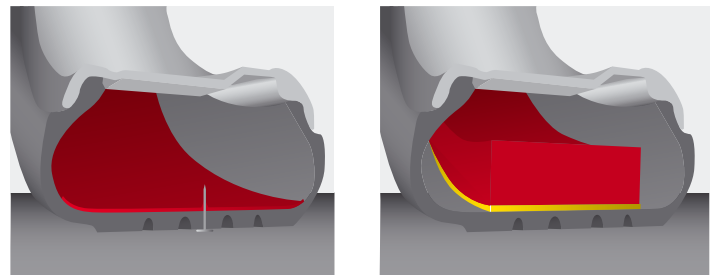

Picture 2: Sealant tire equipped with an additional sealant layer.  
Picture 3: Silent tire equipped with a noise-reducing foam

The block contains three images arranged vertically, connected by red plus signs and a large red bracket on the right. The first image shows a bladder being cured in a furnace. The second image shows a bladder being sprayed with a nozzle. The third image shows a bladder being processed in a factory setting.

- 1** **Clean curing operation**  
Customer A, B, C
- 2** **Extend frequency**  
Customer D  
Customer E
- 3** **Extend bladder life**  
Customer E, F

Picture 4: Permanently coated bladders offer advantages such clean curing operation (1), extended spraying frequency (2) and/or an extended bladder life (3).

# PERFORMANCE RECOMMENDATIONS

## Packaging & Storage

- **Rhenoshape®** bladders are packed individually in plastic bags in order to keep them clean and to prevent exposure to ozone/UV-light.
- Keeping the bladders in the original bag is recommended to avoid dust adhesion on the surface or any foreign material.
- Once the **Rhenoshape®** bladder is removed from its bag, avoid the following exposures in order to prevent degradation of the butyl compound that comprises the bladders:
  - light/ultraviolet light (store in a dark place)
  - circulating air (sealed containers)
  - running electrical equipment (electric arcs form ozone)
- Store **Rhenoshape®** bladders in a cool, dry location; heat affects rubber compounds negatively.
- Cardboard boxes provide protection from physical damage and maintain proper storage conditions for long shelf life (30 months).

## Bladder Selection

- The first selection criterion is defining the type of press, as presses have different fit systems. (The Bag O'matic system has the same foot inside diameter on top and bottom, while National Auto Form has the fitment on the bottom side only, etc.)
- After identifying the type of press, it is recommended that the fit dimensions in the rings be verified, all **Rhenoshape®** dimensions are provided in the brochure. First verify whether the inside foot diameter is suitable for the rings and, secondly, verify the bead compression in the cavity of the rings. Low compression may produce leaks, and high compression could create stress zones that will eventually break the bladder.
- When the type of **Rhenoshape®** and the suitable dimensions of the fitment system are defined, the stretching values in the radial direction and the circumferential path must be verified. During the mounting in the rings, the appropriate bead fit should be determined in order to avoid any imperfections (bead twister, out of rings cavity, etc.).
- For further support in selecting the right **Rhenoshape®**, please contact our dedicated Technical Sales Team.

## Installation and Warm-up

- The warm-up is the procedure for heating and stretching the bladder before use after it has been mounted in the press. The internal pressure is increased to extend the bladder diameter. This procedure must be carried out for all new bladders. Proper warm-up helps avoid defects such as trapped air, open cords or inner liner shadow.
- Stretching must not exceed the diameter of the sidewall of the tire mold to prevent asymmetrical deformation.

## Internal Service

- Internal degradation (also called delamination) is routinely related directly to the quality of the internal service. In essence, there must be no oxygen, because oxygen in the internal service is the main propagator of bladder internal surface degradation.
- It is suggested that the internal curing services (steam, inert gas, etc.) must contain less than one part per million of oxygen (maximum 1.5 ppm) and must be free of metallic compounds, especially copper.
- If the quantity of oxygen exceeds the recommended quantity, it can be neutralized by the addition of oxygen scavengers (the most common is hydrazine or similar).

## Pre-treated Bladders

- **Rhenoshape®** bladders are treated externally with a water-based coating specifically developed to reduce new bladder initial tackiness. This treatment provides high anti-adhesive properties, allowing for easy release of the cured tires.



**LANXESS Deutschland GmbH**  
**BU Rhein Chemie**

Kennedyplatz 1  
50569 Cologne, Germany  
Phone: +49 (0)221 8885-0

**LANXESS Deutschland GmbH**  
**BU Rhein Chemie**

Duesseldorfer Str. 23-27  
68219 Mannheim, Germany  
Phone: +49 (0)621-8907-0

**OOO LANXESS**  
**BU Rhein Chemie**

BC Bolshevik, building 12  
Leningradsky avenue, 15  
125040 Moscow  
Russian Federation, RU  
Phone: +7 495 232 0610

**LANXESS Corporation**  
**BU Rhein Chemie**

111 RIDC Park West Drive  
Pittsburgh, PA 15275-1112, USA  
Phone: +1 412-809-1000

**LANXESS Corporation**  
**BU Rhein Chemie**

145 Parker Court  
Chardon, OH 44024, USA  
Phone: +1 440 285 3547

**LANXESS Corporation**  
**BU Rhein Chemie**

5701 Murray Street  
Little Rock, AR 72209, USA  
Phone: +1 501 562 5410

**LANXESS Indústria de Produtos**  
**Químicos e Plásticos Ltda.**  
**BU Rhein Chemie**

Av. Maria Coelho Aguiar 215  
Bloco B, 2º Andar  
05804-902 Jardim São Luis  
São Paulo-SP, Brazil  
Phone: + 55 11 3741 2879

**LANXESS S.A.**  
**BU Rhein Chemie**

Luis María Drago 1555  
B1852LGS Burzaco/Buenos Aires, Argentina  
Phone: +54-11 4002 4100-260

**LANXESS Hong Kong Limited**  
**BU Rhein Chemie**

35/F, Cambridge House,  
Taikoo Place, 979 King's Road  
Island East, Hongkong, PR China  
Phone: +852-35268885

**Rhein Chemie (Qingdao) Ltd.**  
**BU Rhein Chemie**

43 Siliubei Road  
Li Cang District  
Qingdao 266043, PR China  
Phone: +86-532-8482 9196

**LANXESS Chemical (China) Co., Ltd.**  
**BU Rhein Chemie**

6F, 5 Corporate Avenue  
150 Hu Bin Road, Huangpu District  
200021 Shanghai, PR China  
Phone: +86 21 6109 6624

**LANXESS K.K.**  
**BU Rhein Chemie**

Marunouchi Kitaguchi, Bldg. 23 F  
1-6-5 Marunouchi, Chiyoda-ku  
Tokyo 100-8215, Japan  
Phone: +81-3-5293-8041

**LANXESS India Private Limited**  
**BU Rhein Chemie**

LANXESS House  
Plot No. A-162-164  
Road No. 27, MIDC, Wagle Estate  
Thane (W) – 400 604  
Maharashtra, India  
Phone: +91 22 2587 1000

**LANXESS**  
Energizing Chemistry

rch.lanxess.com  
rubber.additives@lanxess.com

This information and our technical advice – whether verbal, in writing or by way of trials – is subject to change without notice and given in good faith but without warranty or guarantee, express or implied, and this also applies where proprietary rights of third parties are involved. Our advice does not release you from the obligation to verify the information currently provided – especially that contained in our safety data and technical information sheets – and to test our products as to their suitability for the intended processes and uses. The application, use and processing of our products and the products manufactured by you on the basis of our technical advice are beyond our control and, therefore, entirely your own responsibility. Our products are sold in accordance with the current version of our General Conditions of Sale and Delivery.

©2020 LANXESS. Rhenodiv® and Rhenoshape®, LANXESS and the LANXESS Logo are trademarks of LANXESS Deutschland GmbH or its affiliates. All trademarks are registered in many countries worldwide.

Please complete for appropriate recommendation

**General**

Name	
E-Mail	
Date	

**Tire and Press**

Tire Size Including Rim Diameter	
Inside Tire Toe to Toe Periphery	
Inside Tire Diameter at Center Line	
Press Type	
Clamping Type in the Press (BOM/NAF/Asymmetric)	

**Current Bladder**

Name and Code of Supplier	
Foot Inside Diameter (B or B1, B2)	
Foot Height (E or E1, E2)	
Foot Width (F or F1, F2)	

**Clamping** (if non symmetrical, complete for upper and lower diameter)

Diameter B	
Dimension E	
Dimension F	
Dimension G	

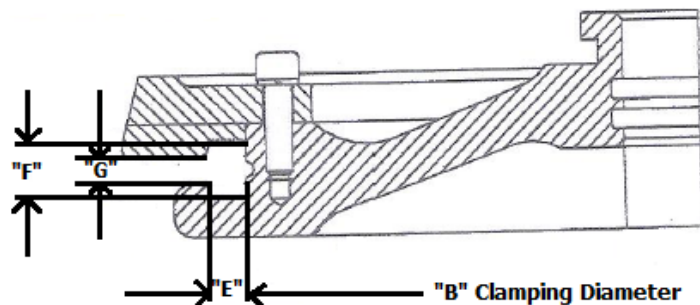
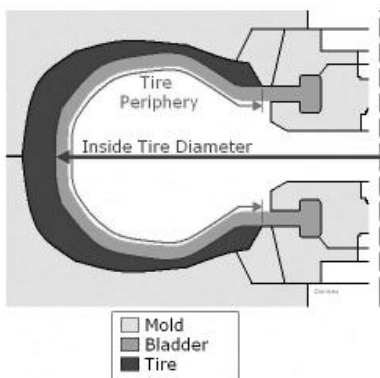

Clamping type in the press

BOM (Bag O'Matic)

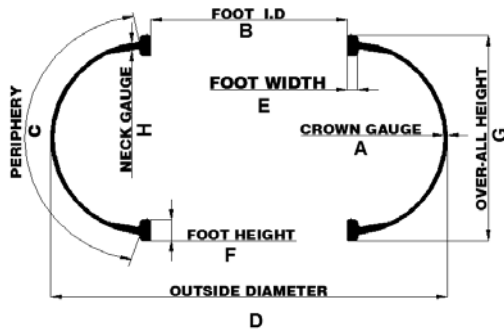

Toroidal (Radial tires)

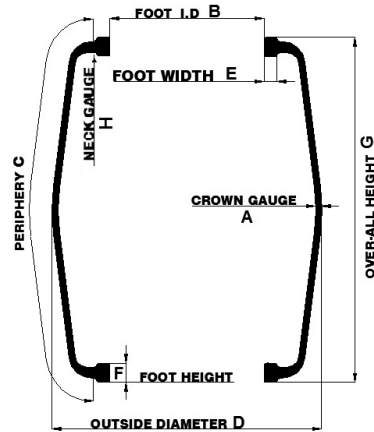

Barrel (Bias Tires)

National Autoform (NAF) /Bagwell

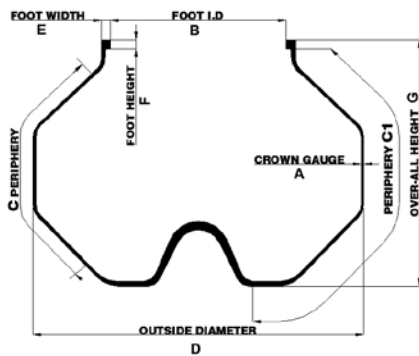

NRM / Closed End

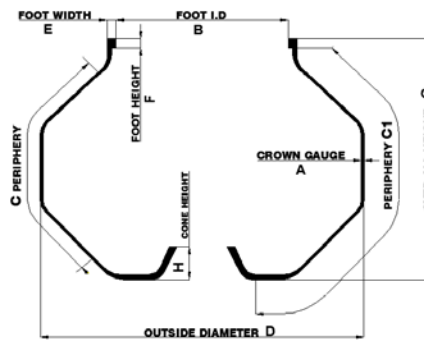

Center Post (Cone removed)

Asymmetrical clamping

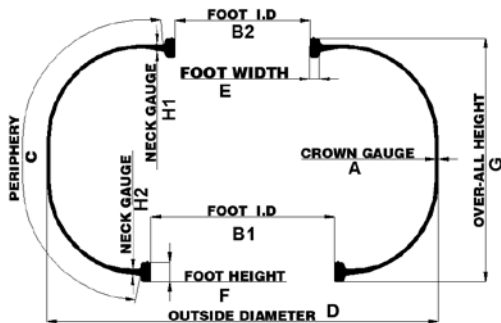

Krupp / Hydraulic

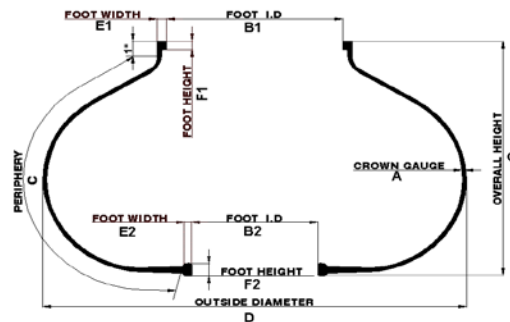

Kobe Bagwell



Krupp or Hydraulic - Toroidal Type

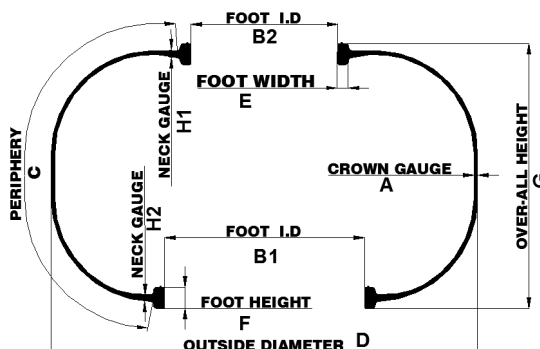

Rhenoshape	Code	A mm	B1 mm	B2 mm	C mm	D mm	E mm	F mm	G mm	H1 mm	H2 mm	Weight kg	Box pcs
13RCK390/4	RBC740	4.3	225	165	390	480	12.5	23.2	235	7.5	7.5	2.79	65
13RCK440/4	RBC741	4.5	225	165	440	480	12.5	23.2	285	8.0	8.0	3.29	60
13RCK516/4	RBC766	4.5	225	165	516	570	15.3	24.2	440	7.5	7.5	4.22	40
18RCK725/8	RBC224	8.0	355	290	725	810	18.5	27.0	480	13.0	13.0	14.30	12
18RCK727/7		8.0	355	290	727	810	18.5	27.0	480	13.0	13.0	14.30	12
18RCK705/9	8552	8.9	356	299	705	660	15.2	26.0	529	16.0	16.0	15.20	8

With respect to production sites in all world regions technical data sheets may vary in details among regions. For regional versions would you please contact your local sales representative.

Our technical advice - whether verbal, in writing or by way of trials - is given in good faith but without warranty, and this also applies where proprietary rights of third parties are involved. It does not release you from the obligation to test the products supplied by us as to their suitability for the intended processes and uses. The application, use and processing of the products are beyond our control and, therefore, entirely your own responsibility. Should, in spite of this, liability be established for any damage, it will be limited to the value of the goods delivered by us and used by you. We will, of course, provide products of consistent quality within the scope of our General Conditions of Sale and Delivery.



Lanxess Deutschland GmbH  
BU Rhein Chemie Additives  
Duesseldorfer Strasse 23-27  
68219 Mannheim, Germany  
Phone: +49 (0)621-8907-0

Krupp or Hydraulic - Toroidal Type

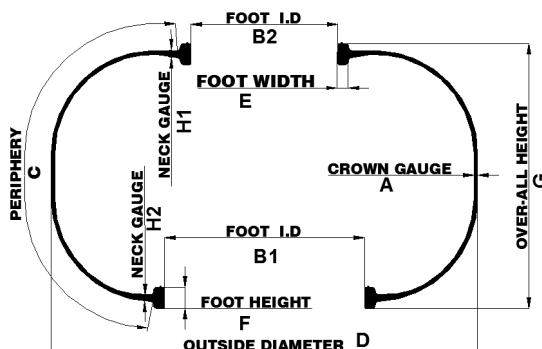

Rhenoshape	Code	A mm	B1 mm	B2 mm	C mm	D mm	E mm	F mm	G mm	H1 mm	H2 mm	Weight kg	Box pcs
13RCK390/4	RBC740	4.3	225	165	390	480	12.5	23.2	235	7.5	7.5	2.79	65
13RCK440/4	RBC741	4.5	225	165	440	480	12.5	23.2	285	8.0	8.0	3.29	60
13RCK516/4	RBC766	4.5	225	165	516	570	15.3	24.2	440	7.5	7.5	4.22	40
18RCK725/8	RBC224	8.0	355	290	725	810	18.5	27.0	480	13.0	13.0	14.30	12
18RCK727/7		8.0	355	290	727	810	18.5	27.0	480	13.0	13.0	14.30	12
18RCK705/9	8552	8.9	356	299	705	660	15.2	26.0	529	16.0	16.0	15.20	8

With respect to production sites in all world regions technical data sheets may vary in details among regions. For regional versions would you please contact your local sales representative.

Our technical advice - whether verbal, in writing or by way of trials - is given in good faith but without warranty, and this also applies where proprietary rights of third parties are involved. It does not release you from the obligation to test the products supplied by us as to their suitability for the intended processes and uses. The application, use and processing of the products are beyond our control and, therefore, entirely your own responsibility. Should, in spite of this, liability be established for any damage, it will be limited to the value of the goods delivered by us and used by you. We will, of course, provide products of consistent quality within the scope of our General Conditions of Sale and Delivery.



Lanxess Deutschland GmbH  
BU Rhein Chemie Additives  
Duesseldorfer Strasse 23-27  
68219 Mannheim, Germany  
Phone: +49 (0)621-8907-0

Barrel Type for Bias Tires

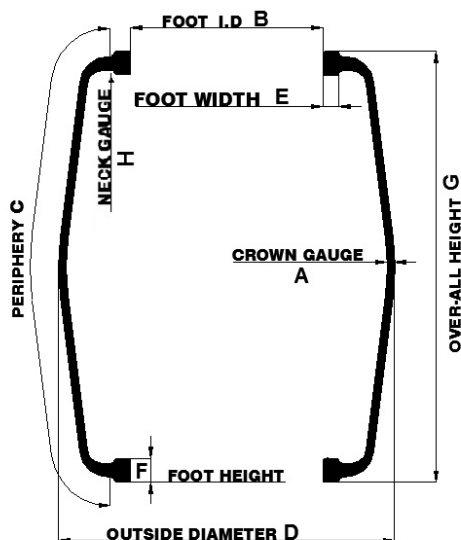

Rhenoshape	Code	A mm	B mm	C mm	D mm	E mm	F mm	G mm	H mm	Weight kg	Box pcs
10RCB419/8	7370	7,6	159	419	292	11,7	20,8	399	9,1	3,30	36
12RCB450/7	RBC827	7,0	203	450	390	12,5	18,5	355	7,5	3,89	45
13RCB389/7	RBC771	7,0	215	389	320	12,3	23,2	380	8,0	3,06	45
13RCB509/7	RBC772	7,0	215	509	320	12,5	23,2	500	8,0	3,93	35
13RCB359/8	6299	8,4	218	359	330	12,7	20,8	337	9,5	3,50	60
13RCB410/8	6228	8,4	218	410	386	12,7	20,8	346	9,5	4,40	40
13RCB474/8	7632	8,4	218	474	386	12,7	20,8	407	9,5	5,00	50
14RCB456/8	6390	8,4	248	456	389	12,7	20,8	421	9,50	5,10	50
14RCB366/7	RBC768	7,0	250	366	378	12,5	23,0	340	8,5	3,54	32
15RCB449/6	RBC053	6,2	276	449	410	12,3	23,3	426	9,3	4,42	32
15RCB462/8	6230	8,4	276	462	405	12,7	20,8	429	8,8	5,40	40
15RCB499/8	6391	8,4	276	499	409	12,7	21,8	464	9,5	6,00	40
15RCB510/7	RBC767	7,0	276	510	410	12,5	21,3	476	9,5	5,10	28
15RCB510/8	RBC054	8,5	276	510	410	12,3	23,3	476	9,5	6,05	28
15RCB538/9	6319	8,9	276	538	445	12,7	21,8	469	9,5	7,40	30
15RCB743/11	6321	11,2	276	743	445	12,7	21,8	666	9,5	10,50	25
15RCB626/9	6320	9,0	276	626	445	12,7	21,8	558	8,7	8,30	25
15RCB204/6	RBC535	6,3	285	204	354	7,8	19,8	180	6,50	1,74	70
16RCB940/11	9340	10,9	305	940	584	12,7	31,8	893	10,7	17,30	10
16RCB991/11	9341	10,9	305	991	584	12,7	31,8	944	10,7	18,00	20
17RCB140/7	RBC514	7,0	310	140	370	10,0	15,0	150	8,0	1,50	80
17RCB170/7	RBC515	7,0	310	170	370	10,0	16,0	180	8,0	1,86	80

Rhenoshape	Code	A mm	B mm	C mm	D mm	E mm	F mm	G mm	H mm	Weight kg	Box pcs
17RCB265/6	RBC520	6,0	324	265	395	8,0	14,0	233	6,7	2,16	60
18RCB154/6	RBC506	6,0	355	154	422	8,5	14,2	151	6,0	1,68	80
18RCB194/6	RBC507	6,0	355	194	422	8,5	14,2	191	6,0	2,02	70
18RCB560/9	RBC403	9,0	355	560	545	16,0	26,0	520	14,0	9,52	15
18RCB670/10	RBC404	10,0	355	670	545	14,0	25,5	630	13,8	12,35	13
18RCB138/6	RBC504	6,0	360	175	428	8,0	16,0	160	7,0	1,69	70
19RCB243/6	RBC518	6,0	373	243	442	8,0	14,0	210	6,5	2,20	60
19RCB275/6	RBC519	6,0	373	275	442	8,0	14,0	244	6,7	2,48	60
20RCB569/8	RBC781	8,5	381	569	560	13,5	26,5	527	13,5	10,95	15
20RCB615/11	8376	11,2	381	615	572	12,7	25,4	530	11,7	13,90	15
20RCB683/10	RBC782	10,0	381	683	560	13,5	27,0	641	13,5	14,08	13
20RCB443/11	3863	11,2	384	443	514	12,7	25,4	406	11,7	8,80	20
20RCB536/11	6236	11,2	384	536	523	12,7	25,4	503	11,0	10,60	15
20RCB656/11	6226	11,2	384	656	562	12,7	25,4	612	11,3	13,20	15
22RCB230/6	RBC516	6,0	420	230	501	8,0	14,0	190	6,7	2,47	60
22RCB672/10	RBT027	10,0	422	672	558	18,5	26,0	620	16,0	15,22	12
22RCB338/5	RBC517	5,0	430	338	590	10,0	18,0	290	5,5	3,64	54
24RCB557/16	7646	16,0	445	557	660	16,0	31,8	453	16,0	18,30	10
24RCB684/16	7647	16,0	445	684	660	16,0	31,8	580	16,0	22,50	6
24RCB864/16	7651	16,0	445	864	699	16,0	31,8	758	16,0	28,50	8
24RCB965/16	7652	16,0	445	965	699	16,0	31,8	860	16,0	32,70	8
24.5RCB1145/16	9373	16,0	467	1145	762	16,0	31,8	1041	16,0	41,30	9
24RCB716/10	RBT077	10,0	482	716	686	18,5	25,5	664	15,5	19,75	10
24RCB934/10	RBT078	10,0	482	934	762	18,0	26,0	858	16,5	26,70	10
26RCB935/11	RBT103	11,0	533	935	813	18,0	26,0	864	16,5	29,40	8
28RCB1112/11	RBT889	11,0	535	1112	1252	13,5	25,3	1040	15,5	34,90	6
26RCB693/16	7662	16,0	546	693	756	16,0	31,8	591	15,3	27,40	6
26RCB744/16	7661	16,0	546	744	756	16,0	31,8	641	16,0	29,60	6
26RCB826/16	7663	16,0	546	826	756	14,3	26,3	724	16,0	32,30	10
26RCB959/16	7664	16,0	546	959	756	16,0	31,8	857	16,0	38,10	9
26RCB961/20	4780	19,6	546	961	763	16,0	31,8	857	16,0	44,10	3
26RCB1137/19	8409	19,1	546	1137	787	16,0	31,8	1041	16,0	48,10	6
28RCB655/16	11478	16,0	584	655	756	16,0	31,8	591	16,0	27,40	10
28RCB683/10	RBT079	10,0	584	683	730	18,0	26,0	635	16,0	21,65	10
28RCB705/16	11477	16,0	584	705	756	16,0	31,8	641	16,0	28,60	10
28RCB788/16	11479	16,0	584	788	756	16,0	31,8	724	16,0	31,60	10
28RCB921/16	11480	16,0	584	921	756	16,0	31,8	857	16,0	38,10	10
30RCB1220/14	11475	14,0	648	1220	965	16,0	38,1	1057	16,0	55,80	5
32RCB986/14	8358	14,0	680	986	965	16,0	31,8	853	16,0	45,60	6
32RCB1189/14	8359	14,0	680	1189	965	16,0	31,8	1057	16,0	54,40	6
32RCB1448/14	10098	14,0	686	1448	991	14,2	31,8	1382	16,0	67,10	4
34RCB843/10	RBT081	10,0	736	843	914	18,0	25,0	795	15,5	34,00	8
34RCB707/20	11551	19,8	737	707	967	16,0	31,8	593	16,0	40,50	6
34RCB845/10	11483	10,2	737	845	967	16,0	31,8	752	16,0	31,30	9

Rhenoshape	Code	A mm	B mm	C mm	D mm	E mm	F mm	G mm	H mm	Weight kg	Box pcs
34RCB694/20	4781	19,8	749	694	967	16,0	31,8	593	16,0	40,50	6
34RCB858/10	4746	10,2	749	858	967	16,0	31,8	752	16,0	31,30	9
34RCB1016/12	7106	12,2	749	1016	965	16,0	33,8	918	16,0	44,00	8
36RCB560/16	11454	16,0	788	560	1005	14,0	22,1	500	11,9	29,00	10
38RCB690/15	11324	15,0	826	690	1120	14,0	25,4	600	11,9	37,10	8
38RCB740/15	11325	15,0	826	740	1120	14,0	25,4	650	11,9	42,30	8
38RCB835/15	11326	15,0	826	835	1120	14,0	25,4	745	11,9	44,90	8
38RCB960/15	11328	15,0	826	962	1120	14,0	25,4	860	15,0	51,70	7
38RCB1040/15	11329	15,0	826	1040	1120	14,0	22,1	950	15,0	55,00	7
38RCB1130/15	11331	15,0	826	1130	1120	14,0	22,1	1040	11,9	59,40	5
38RCB1260/15	11453	15,0	826	1260	1120	14,0	22,1	1170	11,9	68,20	5
38RCB1016/12	10928	12,2	838	1016	1016	16,0	25,4	920	16,0	50,10	8
44RCB505/12	11332	12,4	975	505	1120	16,0	35,1	450	11,9	31,40	8
44RCB540/12	11333	12,4	975	540	1120	16,0	35,1	485	11,9	31,80	12
44RCB605/12	11468	12,4	975	605	1120	16,0	35,1	550	11,9	35,00	5

**With respect to production sites in all world regions technical data sheets may vary in details among regions. For regional versions would you please contact your local sales representative.**

Our technical advice - whether verbal, in writing or by way of trials - is given in good faith but without warranty, and this also applies where proprietary rights of third parties are involved. It does not release you from the obligation to test the products supplied by us as to their suitability for the intended processes and uses. The application, use and processing of the products are beyond our control and, therefore, entirely your own responsibility. Should, in spite of this, liability be established for any damage, it will be limited to the value of the goods delivered by us and used by you. We will, of course, provide products of consistent quality within the scope of our General Conditions of Sale and Delivery.



Lanxess Deutschland GmbH  
 BU Rhein Chemie Additives  
 Duesseldorfer Strasse 23-27  
 68219 Mannheim, Germany  
 Phone: +49 (0)621-8907-0

Toroidal for Radial Tires

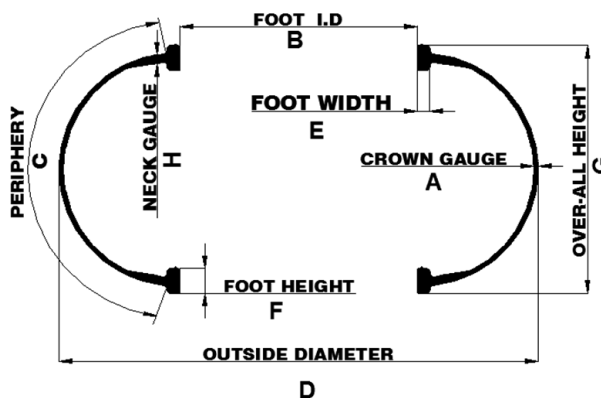

Rhenoshape	Code	A mm	B mm	C mm	D mm	E mm	F mm	G mm	H mm	Weight kg	Box pcs
12RCT280/4	RBC327	4,2	202	280	400	12,2	22,5	220	6,5	1,85	80
13RCT310/4	RBC310	4,2	225	310	425	12,5	23,2	218	7,5	2,19	80
13RCT330/4	RBC350	4,2	225	330	455	12,1	23,1	235	7,5	2,47	70
13RCT355/4	RBC351	4,2	225	355	455	12,5	23,2	267	7,5	2,59	65
13RCT356/6	RBC251	6,0	225	356	455	12,0	23,0	267	6,5	3,10	65
13RCT359/4	RBC770	4,2	225	359	425	12,0	23,0	268	7,3	2,45	70
13RCT395/4	RBC352	4,2	225	395	455	12,3	23,2	300	7,5	2,72	60
14RCT320/4	RBC353	4,2	251	320	460	12,5	23,2	233	7,5	2,49	70
14RCT369/4	RBC762	4,5	251	369	485	14,0	24,0	263	8,0	3,10	60
14RCT370/4	RBC354	4,3	251	370	485	12,2	23,5	263	7,5	2,90	60
14RCT403/4	9847	4,2	251	403	483	12,7	20,8	296	8,0	3,30	72
14RCT405/4	RBC368	4,2	251	405	485	12,2	23,2	305	7,5	3,20	56
14RCT445/4	RBC355	4,2	251	445	485	12,5	23,2	339	7,5	3,32	52
14RCT466/4	RBC780	4,2	251	466	485	12,5	21,2	365	7,5	3,59	52
15RCT357/4	RBC357	4,5	276	357	520	12,0	23,2	256	7,5	3,24	60
15RCT415/4	RBC326	4,5	276	415	520	12,4	23,3	320	7,5	3,50	52
15RCT416/6	RBC226	6,0	276	416	520	12,7	23,5	320	8,0	4,30	52
15RCT460/4	RBC259	4,5	276	460	560	12,5	23,2	360	6,5	3,97	40
15RCT462/6	RBC059	6,0	276	462	560	12,0	23,5	360	8,0	5,06	40
15RCT505/4	RBC347	4,5	276	505	560	12,5	23,5	400	6,5	4,21	40
15RCT559/4	9086	4,2	276	559	597	12,7	20,8	403	8,0	4,90	30
15RCT498/6	RBC247	6,4	286	499	584	15,2	22,4	368	9,4	6,27	30
15RCT393/6	RBC408	6,0	286	394	495	12,7	21,5	305	7,8	4,00	50

Rhenoshape	Code	A mm	B mm	C mm	D mm	E mm	F mm	G mm	H mm	Weight kg	Box pcs
16RCT366/4	RBC334	4,5	301	366	490	12,5	23,5	302	7,0	3,47	40
16RCT380/4	RBC234	4,5	301	380	490	12,2	23,5	314	8,0	3,60	40
16RCT381/6	RBC034	6,0	301	381	490	12,2	23,0	314	7,5	4,24	40
16RCT430/5	RBC246	5,0	301	430	585	12,3	23,2	320	7,5	4,17	40
16RCT432/6	RBC046	6,2	301	432	585	12,3	23,0	320	7,6	5,16	40
16RCT490/5	RBC248	5,0	301	490	585	12,5	23,2	380	7,5	4,85	36
16RCT492/6	RBC048	6,0	301	492	585	12,5	23,2	380	7,5	5,55	36
16RCT550/6	RBC264	6,0	301	550	640	12,5	23,0	410	8,0	6,53	36
16RCT394/6	RBC420	6,0	311	396	508	12,7	21,5	330	7,5	4,15	50
16RCT742/8	RBC796	8,5	311	742	774	17,0	26,0	507	16,5	13,40	12
17RCT367/4	RBC382	4,5	327	367	520	12,3	23,1	320	7,6	3,69	52
17RCT410/6	RBC283	6,0	327	410	580	12,2	23,5	320	8,0	4,78	40
17RCT485/6	RBC482	6,0	327	485	640	12,5	23,2	350	8,0	5,68	36
17RCT508/6	RBC769	6,0	327	508	640	12,5	23,2	373	8,0	6,34	36
18RCT363/6	RBC452	6,0	353	363	525	12,5	23,2	312	7,5	4,32	40
18RCT406/6	RBC453	6,0	353	406	525	12,5	23,2	355	7,5	4,60	40
18RCT435/6	RBC454	6,0	353	435	585	12,7	23,5	360	8,0	5,18	40
18RCT510/6	RBC263	6,0	353	510	650	12,5	23,2	390	8,0	6,60	36
18RCT579/8	RBC779	8,0	355	579	711	15,0	25,5	406	15,0	11,31	15
18RCT666/8	RBC777	8,0	355	666	711	15,0	25,5	505	16,0	13,20	10
19RCT403/6	RBC826	6,0	382	403	560	12,5	23,0	350	8,0	5,30	40
19RCT459/6	RBC825	6,0	382	459	620	12,5	23,0	392	8,0	6,02	40
20RCT401/6	RBC832	6,0	403	402	585	12,5	23,5	340	8,0	5,20	40
20RCT464/6	RBC050	6,0	404	464	630	12,3	23,2	398	7,5	5,47	40
20RCT465/5	RBC450	5,0	404	465	630	12,3	23,2	398	7,5	5,28	40
22.5RCT600/8	RBC171	8,5	415	600	790	18,5	26,0	440	13,5	12,78	12
22.5RCT605/8	RBC170	8,5	419	606	790	18,0	26,0	440	13,5	10,88	12
22.5RCT606/6	RBC447	6,0	419	606	790	18,0	26,0	440	13,0	10,88	12
22.5RCT690/8	RBC245	7,5	419	690	790	16,5	26,0	530	13,5	14,16	10
22.5RCT696/6	RBC446	6,0	419	696	790	16,5	26,0	530	13,5	12,20	10
22.5RCT602/8	RBC071	8,5	427	602	790	12,5	26,0	440	14,0	12,40	12

With respect to production sites in all world regions technical data sheets may vary in details among regions. For regional versions would you please contact your local sales representative.

Our technical advice - whether verbal, in writing or by way of trials - is given in good faith but without warranty, and this also applies where proprietary rights of third parties are involved. It does not release you from the obligation to test the products supplied by us as to their suitability for the intended processes and uses. The application, use and processing of the products are beyond our control and, therefore, entirely your own responsibility. Should, in spite of this, liability be established for any damage, it will be limited to the value of the goods delivered by us and used by you. We will, of course, provide products of consistent quality within the scope of our General Conditions of Sale and Delivery.

---



**Lanxess Deutschland GmbH**

**BU Rhein Chemie Additives**

Duesseldorfer Strasse 23-27

68219 Mannheim, Germany

Phone: +49 (0)621-8907-0



NRM / Closed End

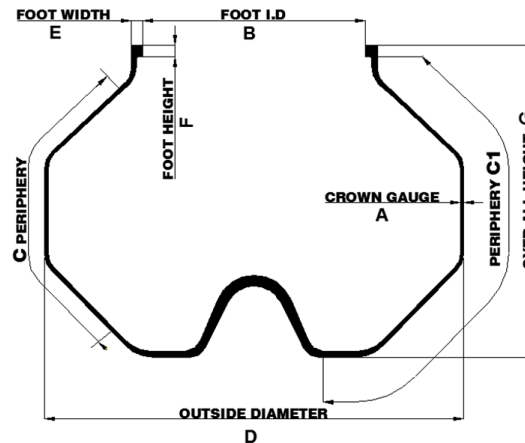

Rhenoshape	Code	A mm	B mm	C1 mm	D mm	E mm	F mm	G mm	Weight kg	Box pcs
13RCA268/4	RBC821	4,5	240	322	450	15,0	15,0	280	3,16	56
13RCA287/4	RBC295	4,5	271	407	467	14,3	14,6	300	3,24	56
13RCA364/7	4493	6,6	271	447	419	14,5	13,7	394	4,70	28
13RCA343/4	RBC776	4,5	271	458	467	14,3	14,6	352	3,48	30
13RCA340/4	RBC301	4,3	271	460	510	14,3	14,6	330	3,68	52
13RCA402/4	RBC302	4,5	271	510	510	14,3	14,6	380	3,82	40
13RCA412/6	RBC785	6,0	271	528	467	13,5	14,0	420	4,93	25
13RCA463/6	RBC805	6,2	271	550	416	13,2	13,6	504	5,44	36
13RCA450/5	RBC476	5,0	271	558	575	14,3	14,6	408	5,09	25
13RCA491/4	9093	4,2	271	574	559	13,7	14,5	419	5,20	50
13RCA515/5	RBC472	5,4	271	622	575	14,3	14,6	455	6,04	25
13RCA544/7	4748	6,6	271	627	445	14,5	13,7	584	6,70	30
14RCA337/4	RBC856	4,5	330	402	490	14,3	14,6	382	4,27	45

## Center Post (Cone Removed)

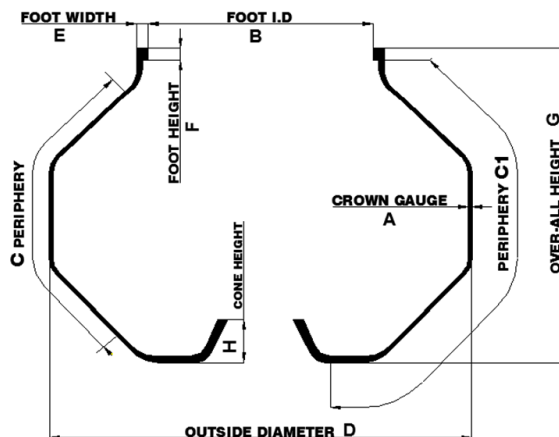

Rhenoshape	Code	A mm	B mm	C1 mm	D mm	E mm	F mm	G mm	H mm	Weight kg	Box pcs
13RCA287/4-R	RBC900	4,5	271	407	467	14,3	14,6	300	30	3,12	56
13RCA340/4-R	RBC824	4,3	271	460	510	14,3	14,6	330	30	3,50	52
13RCA402/4-R	RBC774	4,5	271	510	510	14,3	14,6	360	30	3,63	40
13RCA445/4-R	9089M	4,3	271	528	467	14,3	14,0	420	38	4,80	50
13RCA450/5-R	RBC778	5,0	271	558	575	14,3	14,6	408	30	4,86	25

With respect to production sites in all world regions technical data sheets may vary in details among regions. For regional versions would you please contact your local sales representative.

Our technical advice - whether verbal, in writing or by way of trials - is given in good faith but without warranty, and this also applies where proprietary rights of third parties are involved. It does not release you from the obligation to test the products supplied by us as to their suitability for the intended processes and uses. The application, use and processing of the products are beyond our control and, therefore, entirely your own responsibility. Should, in spite of this, liability be established for any damage, it will be limited to the value of the goods delivered by us and used by you. We will, of course, provide products of consistent quality within the scope of our General Conditions of Sale and Delivery.



Lanxess Deutschland GmbH  
 BU Rhein Chemie Additives  
 Duesseldorfer Strasse 23-27  
 68219 Mannheim, Germany  
 Phone: +49 (0)621-8907-0